

**ELECTRIC TAPPING MACHINE  
WITH BALANCED ARM  
M2-M14 (M16)**

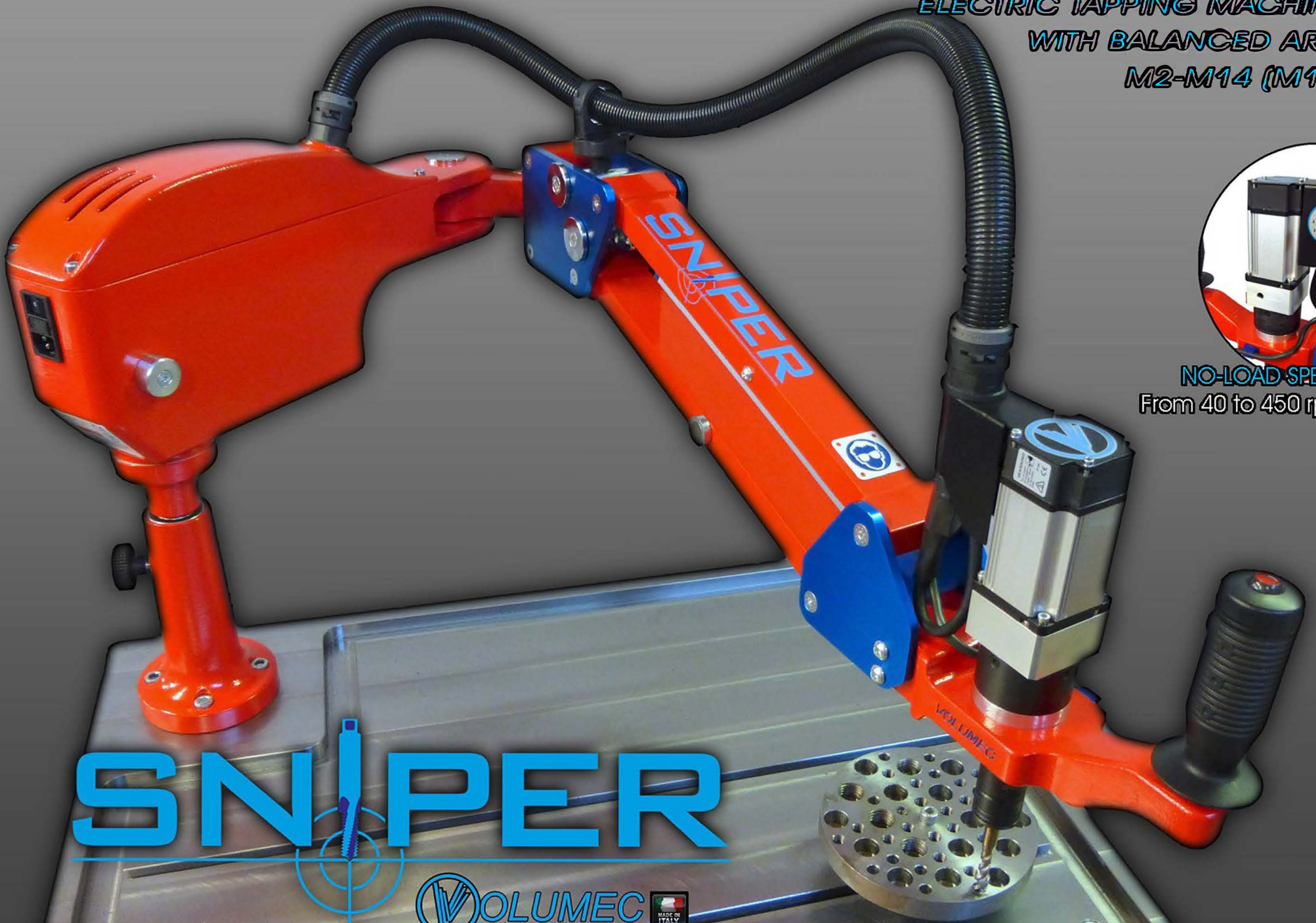

**NO-LOAD SPEED  
From 40 to 450 rpm**



**SNIPER**



# SNIPER 400

Tapping capacity in Steel  
M2 - M14 (M16 Al.)

Speed Regulation  
40-450 rpm

Torque max.  
39 Nm

Spindle  
Ø 19 mm (GR1)

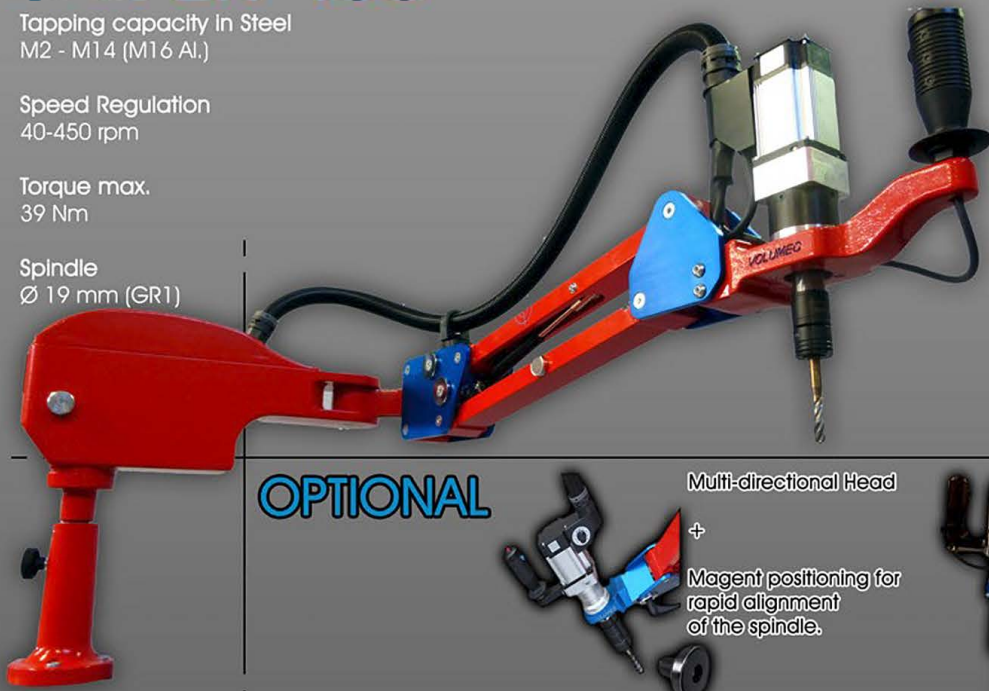

## OPTIONAL



Multi-directional Head

+

Magnet positioning for rapid alignment of the spindle.



Depth Sensor with automatic reverse

## ACCESSORIES



Quick change bush with or without safety clutch  
M2-M16 GR1

Die-holder for external threads



Work-table with T-slot  
800 x 600 mm H = 830 mm

Thickness of the working plane 30 mm

Weight 150Kg



Bush with chuck adapter (1-13 mm) for drilling, countersinking, screwing



Trolley with wheels and brake  
850 x 750 mm H= 870mm

Weight: 65 kg

## MACHINE CHARACTERISTICS

- Articulated balanced arm made entirely of special aluminum, which guarantee high stability and a precise holes alignment.
- Electric Brushless Motor 400 W (220 V) complete integrated in the arm, with high performance, minimum noise and low electricity consumption.
- Large range of adjustment of tapping speed without the use of additional modules
  - Maximum reverse speed for the extraction of the tool
  - Articulated arm with adjustable balance
- Possibility to tap also blind hole with the quick change holders with safety and adjustable clutch to prevent tap breakage.

## WORKING AREA

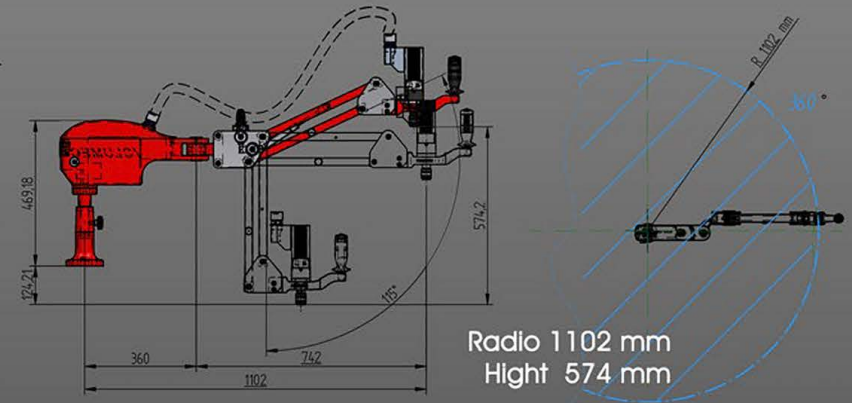

Volumec - Via Cal della Madonna 54/D  
31010 Farra di Soligo (TV) - ITALY  
Phone +39 0438 900299 - Fax +39 0438 189651  
www.volumec.it - info@volumec.it

North American Master Distributor

**KEYSTONE**  
FASTENING TECHNOLOGIES

Keystone Fastening Technologies

114 VIP Drive  
Wexford, PA 15090  
Phone: (800) 659-5972

www.keystonefastening.com - info@keystonefastening.com